

In Pursuit of Cyclopropanethione: Cyclopropanethione S-Oxide and S,S-Dioxide¹

Eric Block,^{*,†} Adrian Schwan,^{†,2} and David A. Dixon^{*,‡}

Contribution from the Department of Chemistry, State University of New York at Albany, Albany, New York 12222, and Central Research and Development Department, E. I. du Pont de Nemours and Co., Wilmington, Delaware 19880. Received October 1, 1991

Abstract: The geometries of cyclopropanethione (**1a**), methylenethiirane (**2a**), cyclopropanethione S-oxide (**1b**), methylenethiirane S-oxide (**2b**), cyclopropanethione S,S-dioxide (**1c**), methylenethiirane S,S-dioxide (**2c**), thioformaldehyde S,S-dioxide (sulfene), and the tetramethyl derivatives of **1b** and **2b**, tetramethylcyclopropanethione S-oxide (**1d**) and 3,3-dimethyl-2-isopropylidenethiirane S-oxide (**2d**), respectively, were optimized at the SCF level by using ab initio molecular orbital theory with a polarized double zeta basis set. The difference in energy for each pair of isomers is as follows: **2a** more stable than **1a** by 6.4 kcal/mol; **1b** more stable than **2b** by 8.2 kcal/mol; **2c** more stable than **1c** by 0.2 kcal/mol; and **1d** more stable than **2d** by 0.3 kcal/mol. Fluorodesilylation of 1-(trimethylsilyl)cyclopropanesulfonyl chloride (**3**) in the presence of 1-(*N,N*-diethylamino)-1-propyne affords 4-(*N,N*-diethylamino)-3-methyl-2-thiaspiro[3.2]hex-3-ene 2,2-dioxide (**19**) in 56% yield by way of **1c**. Treatment of cyclopropanesulfonyl chloride (**7**) with triethylamine gives triethylamine hydrochloride in 90% yield along with *S*-1-chlorocyclopropyl cyclopropanethiosulfonate (**18**), *S*-cyclopropyl cyclopropanethiosulfonate (**9**), and cyclopropanesulfonyl chloride (**8**). The formation of these latter four products is consistent with the intermediacy of **1b**. Attempts to fluorodesilylate 1-(trimethylsilyl)cyclopropyl aryl disulfides generating cyclopropanethione **1a** itself led instead to products derived from rearrangement of arylthio α -cyclopropyl carbanions. A cyclopropanethione, dispiro[2.0.2.1]heptane-7-thione (**20**), which is calculated to be stable relative to its methylenethiirane tautomer, is proposed.

Introduction

While significant advances have occurred in the preparation and trapping of reactive thiocarbonyl compounds such as thioaldehydes³ and their *S*-monoxides (sulfines⁴) and *S,S*-dioxides (sulfenes⁴), cyclopropanethione (**1a**), the simplest cyclic thione, remains unknown. Interconversion of **1a** and its valence tautomer allene episulfide (**2a**, methylenethiirane)^{5a-c} via a presumed thioallyl intermediate^{5a,d,e,6} (Scheme I) is of interest for comparison with similar rearrangements of methylenecyclopropanes,^{7a,b} cyclopropanones,^{7c,d} cyclopropanimines,^{7e-g} and related heteromethylenecyclopropanes. Because **1a** is unstable relative to **2a**, all attempts to date to make **1a** and its simple derivatives have led instead to **2a** (Scheme II).⁵

Isomerization of **1a** to **2a** should be retarded at lower temperatures. We therefore sought nonpyrolytic routes to **1a**. We also considered similar routes to the unknown *S*-oxides of **1a**, cyclopropanethione *S*-oxide (**1b**) and *S,S*-dioxide (**1c**), speculating that the relative stabilities of valence tautomeric pairs **1b**/methylenethiirane *S*-oxide (**2b**) and **1c**/methylenethiirane *S,S*-dioxide (**2c**) might be significantly different from that for **1a**/**2a**. While Quast^{5f} and Schaumann⁸ both show that irradiation of peralkylated 1-pyrazoline-4-thione *S*-oxides affords the corresponding allene episulfoxides (e.g., **2d**; eq 1) rather than cyclopropanethione *S*-oxides (e.g., **1d**), it is unclear whether this result is relevant to the question of relative stabilities of unsubstituted **1b** and **2b**.

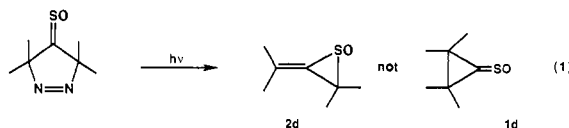

We have combined theoretical and synthetic methods in our pursuit of cyclopropanethione and its *S*-oxides. Theoretical methods have been used to compare the stabilities of the unsubstituted pairs **1a**/**2a**, **1b**/**2b**, and **1c**/**2c** as well as the tetramethyl derivatives of **1b**/**2b**, **1d**/**2d**. The structure and charge distribution of thioformaldehyde *S,S*-dioxide, H₂CSO₂, the simplest sulfene, have also been calculated for comparison with the properties of

Scheme I

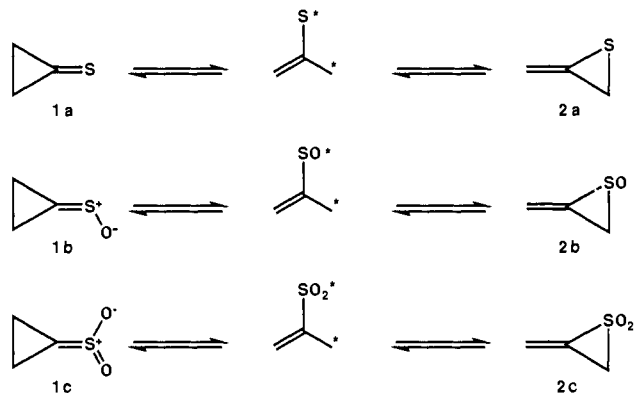

Scheme II

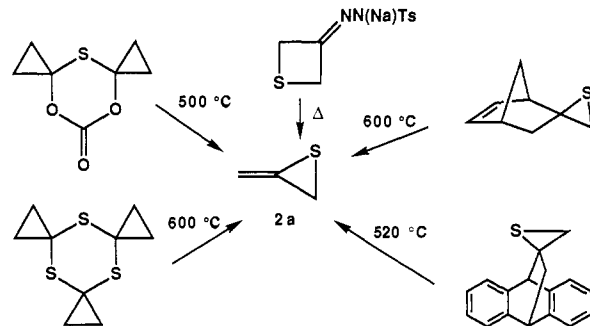

1c. Fluorodesilylation was examined as a method for low-temperature generation of the C=S bonds in **1a-c** in analogy to the

(1) Presented at the 2nd International Conference on Heteroatom Chemistry (ICHAC-2), Albany, NY, July 1989, and the Canadian Society for Chemistry Biannual Symposium on Carbanion Chemistry, Ottawa, ON, Canada, July 1989.

(2) Holder of an NSERC of Canada Postdoctoral Fellowship, 1988-1989. Present address: Department of Chemistry and Biochemistry, University of Guelph, Guelph, Ontario, Canada N1G 2W1.

[†]State University of New York at Albany.

[‡]Du Pont, contribution no. 6026.

Table I. Molecular Geometries^a

(a) 1 and Derivatives							
	1a	H ₂ CS (expt) ^c	1b ^b	H ₂ CSO (exp) ^d	1c	H ₂ CSO ₂	1d
C ₁ -S	1.594	1.611	1.581	1.610	1.544	1.568	1.581
C ₁ -C ₂	1.466		1.463		1.467		1.471
C ₁ -C ₃	1.466		1.472		1.467		1.480
C ₂ -C ₃	1.533		1.523		1.526		1.538
SC ₁ C ₂	148.5		151.7		148.6		151.0
SC ₁ C ₃	148.5		145.8		148.6		146.2
C ₂ C ₁ C ₃	63.0		62.5		62.7		62.8
C ₁ C ₂ C ₃	58.5		59.0		58.6		58.9
H ₁ C ₁ H ₂		116.9		121.9		123.2	
H ₁ C ₁ S ^e		121.6		122.5		118.4	
C ₁ -H ₁ ^f		1.093		1.085		1.069	
C ₁ -H ₂ ^f		1.093		1.077		1.069	
S-O			1.468	1.469	1.428	1.421	1.472
OSC ₁			114.5	114.7	119.7	119.4	114.6
OSO					120.6	121.2	

(b) 2 and Derivatives ^f								
	2a	2a (expt) ^a	thiirane ^h	2b	thiirane S-oxide ⁱ	2c	thiirane S,S-dioxide ⁱ	2d
C ₁ -C ₂	1.315	1.333		1.312		1.311		1.318
C ₂ -C ₃	1.457	1.451	1.484	1.464	1.504	1.533	1.590	1.464
C ₂ -S	1.739	1.732	1.815	1.759	1.822	1.707	1.731	1.760
C ₃ -S	1.837	1.849		1.831		1.754		1.858
C ₁ C ₂ C ₃	145.8	146.2		147.7		150.0		148.5
C ₁ C ₂ S	144.6	143.5		143.8		144.7		141.5
C ₂ C ₃ S	69.5	70.3		68.5		65.3		69.7
C ₂ C ₃ S	62.5	61.9		63.4		62.1		62.7
C ₂ SC ₃	48.0	47.8	48.3	48.1	48.8	52.6	54.7	47.6
S-O				1.479	1.483	1.433	1.439	1.488
OSO						120.7	121.4	

^a Bond distances in angstroms; bond angles in degrees. ^b C₂ is syn to the O atom. ^c Reference 13b. ^d Reference 13a. ^e In CH₂SO, H₁ is syn to O, H₂ is anti to O. ^f C₁ is the exocyclic CH₂ group. ^g Reference 5a. ^h Reference 12a. ⁱ Reference 12b.

application of this procedure to the preparation of allene oxides,^{9a} thials,^{3a} selenaldehydes,^{9b} sulfines,⁴ and sulfenes⁴ (Scheme III). We were optimistic that a fluorodesilylation route to sulfene 1c¹⁰

(3) (a) Krafft, G. A.; Meinke, P. T. *Tetrahedron Lett.* **1985**, 26, 1947. (b) Vedejs, E.; Eberlein, T. H.; Mazur, D. J.; McClure, C. K.; Perry, D. A.; Ruggeri, R.; Schwartz, E.; Stults, J. S.; Varie, D. L.; Wilde, R. G.; Wittenburger, S. *J. Org. Chem.* **1986**, 51, 1556. (c) For trapping of thioacrolein, see: Block, E.; Iyer, R.; Grisoni, S.; Saha, C.; Belman, S.; Lossing, F. P. *J. Am. Chem. Soc.* **1988**, 110, 7813. Block, E.; Zhao, S. H. *Tetrahedron Lett.* **1990**, 31, 5003.

(4) (a) Block, E.; Aslam, M. *Tetrahedron Lett.* **1982**, 23, 4203. (b) Block, E.; Wall, A. *Tetrahedron Lett.* **1985**, 26, 1425. (c) Block, E.; Wall, A. *J. Org. Chem.* **1987**, 52, 809. (d) General review: King, J. F.; Rathore, R. In *The Chemistry of Sulphonic Acids, Esters, and their Derivatives*; Patai, S., Rappoport, Z., Eds.; John Wiley: New York, 1991; pp 697-766.

(5) (a) Block, E.; Penn, R. E.; Ennis, M. D.; Owens, T. A.; Yu, S.-L. *J. Am. Chem. Soc.* **1978**, 100, 7436. (b) Jongejan, E.; Buys, Th. S. V.; Steinberg, H.; de Boer, Th. *Recl. Trav. Chim. Pays-Bas* **1978**, 97, 215. (c) Ando, W.; Itami, A.; Furuhashi, T.; Tokitoh, N. *Tetrahedron Lett.* **1987**, 28, 1787. (d) Ando, W.; Choi, N.; Kabe, Y. *J. Am. Chem. Soc.* **1990**, 112, 4574. (e) Quast concludes that diastereoselective formation of (*E,Z*)-alkylidene thiiranes from photolysis of *cis*- and *trans*-tetraalkyl-1-pyrazoline-4-thiones "is not compatible with equilibrated intermediates nor with thermodynamic product control" and invokes bis-orthogonal thioxyallyl diradicals: Quast, H.; Fuss, A.; Jakobi, H. *Chem. Ber.* **1991**, 124, 1747. (f) Quast, H.; Fuss, A. *Angew. Chem., Int. Ed. Engl.* **1981**, 20, 291. (g) Ando, W. In *Reviews in Heteroatom Chemistry*; Oae, S., Ed.; MYU: Tokyo, 1988; Vol. 1, p 235.

(6) (a) Kikuchi, O.; Nagata, H.; Morihashi, K. *J. Mol. Struct. (THEOCHEM)* **1985**, 124, 261. (b) Bock, H.; Mohmand, S.; Hirabayashi, T.; Semkow, A. *Chem. Ber.* **1982**, 115, 1339. (c) Furuhashi, T.; Ando, W. *Tetrahedron Lett.* **1986**, 27, 4035.

(7) (a) Dowd, P. *Acc. Chem. Res.* **1972**, 5, 242. (b) Berson, J. A. *Ibid.* **1978**, 11, 446. (c) Wasserman, H. H.; Berdahl, D. R.; Lu, T.-J. In *The Chemistry of the Cyclopropyl Group*; Rappoport, Z., Ed.; John Wiley: New York, 1987; Part 2, pp 1455-1532. (d) Turecek, F.; Drinkwater, D. E.; McLafferty, F. W. *J. Am. Chem. Soc.* **1990**, 112, 5892. (e) Quast, H.; Risler, W. *Angew. Chem.* **1973**, 85, 411. (f) L'abbé, G. *Angew. Chem., Int. Ed. Engl.* **1980**, 19, 276. (g) Quast, H.; Jakobi, H. *Chem. Ber.* **1991**, 124, 1613.

(8) Schaumann, E.; Behr, H.; Adiwidjaja, G.; Tangerman, A.; Lammerink, B. H. M.; Zwanenburg, B. *Tetrahedron* **1981**, 37, 219.

(9) (a) Chan, T. H.; Ong, B. S. *J. Org. Chem.* **1978**, 43, 2994. (b) Krafft, G. A.; Meinke, P. T. *J. Am. Chem. Soc.* **1986**, 108, 1314.

Scheme III

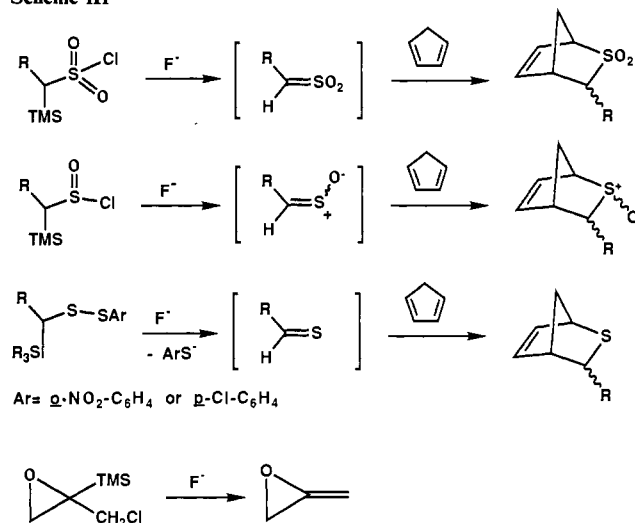

might be facilitated by the electron-withdrawing sulfur functions in precursors such as 1-(trimethylsilyl)cyclopropanesulfonyl chloride (3).

In this paper, we report the surprising conclusions of the theoretical study, present direct experimental evidence for the trapping of 1b and 1c, describe novel chemistry discovered during attempts to generate 1a at or below room temperature, and propose a cyclopropanethione which we calculate to be stable relative to its methylenethiirane tautomer.

(10) Generation of cyclopropanethione S,S-dioxide from cyclopropanesulfonyl chloride: King, J. F.; Lam, J. Y. L.; Ferrazzi, G. Personal communication.

Results and Discussion

Theoretical Calculations. A. Methods. All calculations were done with the program GRADSCF^{11a} on a Cray Y-MP computer system. Geometries were gradient optimized,^{11b} and the force field calculations^{11c} were done analytically. Correlation corrections were done at the MP-2 level^{11d} for the valence electrons at the SCF geometries. Valence double zeta basis sets augmented by polarization functions were used for all atoms. The basis set for H, C, and O is from Dunning and Hay,^{11e} The basis set for S is from McLean and Chandler^{11f} with a *d* polarization exponent of 0.60.

B. Geometries. The calculated geometries are given in Tables Ia/Ib. All of the geometries were found to be minima on the potential energy surface as shown by force field analysis. For thiiranes **2a-c**, only the structure of **2a** is known.^{5a} Structures of the parent thiirane *S*-oxide and *S,S*-dioxide have also been reported.¹² The agreement between the calculated and experimental structures of **2a** is very good. Addition of an O atom (e.g., **2b**) does not lead to substantial changes in the geometry except that the C₂-S bond is predicted to lengthen by 0.02 Å. The C-S-C angle still remains small, less than 50°. Addition of a second O atom to the S (e.g., **2c**) leads to significant changes in the ring. The C₂-C₃ bond lengthens by 0.076 Å relative to the corresponding bond in **2a**, and the C₃-S bond shortens by a comparable amount, 0.083 Å. In contrast to the structure obtained by addition of one O (**2b**), addition of two oxygens (**2c**) leads to a decrease in *r*(C₂-S) of 0.032 Å. The S-O bond lengths decrease by 0.046 Å, consistent with the variations found in other structures (compare thiirane *S*-oxide and *S,S*-dioxide). The angles in the ring change somewhat, by 4-5°, due to the changes in bond length. Substitution of four methyl groups to form **2d** from **2b** leads to only small changes in the geometry.

For **1a** and its *S*-oxides, the only comparisons to experiment that can be made are those for thioformaldehyde, H₂C=S, and its *S*-oxide, H₂C=SO, for which structures are known.^{13a,b} Reasonable agreement with the parameters *r*(C-S), *r*(S-O), and θ (OSC) is found for **1a** and **1b**. Sulfine **1b** has a very similar structure to that of cyclopropanethione (**1a**) just as there is little difference between H₂C=S and H₂C=SO and between structures **2a** and **2b**. Formation of sulfene **1c** leads to only one significant change in the geometry relative to **1a**, namely, shortening of the C=S bond by 0.05 Å. Comparison of the calculated structure of thioformaldehyde *S,S*-dioxide, H₂C=SO₂, to the structures of H₂C=S and **1c** shows that upon going from H₂C=S to H₂C=SO₂ the C=S bond decreases by 0.043 Å, while replacement of the CH₂ group in the latter compound by cyclopropylidene decreases the C=S bond by an additional 0.024 Å.^{13d} There is very little effect on the SO₂ group geometry on going from H₂C=SO₂ to **1c**. As would be expected from our other calculations, the S-O bonds are 0.04 Å shorter in sulfene **1c** compared to sulfine **1b**. Substitution of four methyl groups to form **1d** from

Table II. Calculated Energies

	Total Energies (au)			
	<i>E</i> (SCF)	<i>E</i> (MP-2)	HOMO (eV)	μ (D)
1a	-513.387 250	-513.912 502	8.81	2.86
2a	-513.396 695	-513.922 733	8.94	1.71
1b	-588.214 680	-588.933 566	9.70	5.05
2b	-588.208 841	-588.920 428	10.31	4.77
1c	-633.038 059	-663.937 972	10.30	4.94
2c	-663.046 791	-663.938 337	11.52	5.55
1d	-744.392 159	-745.692 419	9.42	5.47
2d	-744.401 400	-745.691 862	9.07	5.30
CH ₂ SO ₂	-586.175 902	-586.811 670	10.98	3.34

	Energy Differences (kcal/mol)		
	ΔE_{elec} (SCF)	ΔE_{elec} (MP-2)	ΔE_0 (MP-2)
ΔE (1a - 2a)	5.9	6.4	6.4
ΔE (1b - 2b)	-3.7	-8.2	-7.5
ΔE (1c - 2c)	5.5	0.2	0.6
ΔE (1d - 2d)	5.8	-0.3	0.4

1b leads to only small changes in the geometry.

The experimental S-C bond length in thiirane is 1.815 Å with a CSC bond angle of 48.3°. This is a much longer C-S bond than found for the C₂-S bond in **2a** but is shorter than the C₃-S bond in **2a**. Clearly, introduction of the exocyclic double bond leads to significant changes in the geometry. The S-O bond length (1.483 Å) and the CSC bond angle (48.8°) found experimentally for thiirane *S*-oxide^{12b} are similar to the values in **2b**. The C-S bond lengths bracket the experimental length of 1.822 Å found for thiirane *S*-oxide. Good agreement between **2c** and thiirane *S,S*-dioxide for the S-O bond length and the CSC and OSO bond angles is found. Although the C-S distances in **2c** still bracket the S-C distance in thiirane *S,S*-dioxide, the values are now much closer to each other, showing that introduction of the exocyclic double bond has less effect on the structure of **2c** than it does on **2a** or **2b**.

C. Energies and Electronic Properties. The total energies and energy differences are given in Table II. Thiirane **2a** is predicted to be more stable than thione **1a** by 6.4 kcal/mol at the MP-2 level, consistent with the nonobservation of the thione and with expectations based on bond strengths.^{5a} There is essentially no correlation or zero-point energy correction to this difference. Previous calculations indicated **2a** to be more stable than **1a** by 6.2 (STO-3G optimized geometry with a 6-31G basis set and a small CI)^{6a} or 9.6 kcal/mol (MNDO),^{6b} on the other hand, similar calculations indicated cyclopropanone to be more stable than allene oxide by 15.7^{6b} or 23 kcal/mol^{6c} (the latter value coincides well with expectations based on bond strengths^{2a}). In contrast to the above energy differences, sulfine **1b** is predicted to be more stable than heterocyclic isomer **2b** by 8.2 kcal/mol at the MP-2 level. There is a correlation correction of 4.5 kcal/mol favoring **1b**. This is consistent with the short C-S and S-O bonds in the sulfine requiring a large correlation correction. The effect of zero-point energy corrections is to lower this energy difference by 0.7 to 7.5 kcal/mol. At the MP-2 level, sulfene **1c** is predicted to be essentially isoenergetic with isomer **2c**, with **2c** lower in energy by 0.2 kcal/mol. There is a correlation correction of 5.3 kcal/mol favoring sulfene **1c**. The charge distribution in **1c** is similar to that in the parent sulfene, H₂C=SO₂, with the SO₂ group having the same charge distribution.

The addition of methyl groups to **1b** and **2b** to make **1d** and **2d**, respectively, has a significant effect on the energy difference between the two isomers. The effect of tetramethyl substitution is to make the isomers essentially isoenergetic at the MP-2 level, with **1d** more stable than **2d** by 0.3 kcal/mol. There is a significant correlation correction favoring **1d**. The effect of zero-point corrections is to reverse the stability of **1d** and **2d** so that **2d** is now 0.4 kcal/mol more stable than **1d**. Irradiation of substituted 1-pyrazoline-4-thione *S*-oxides leads to allene episulfoxides instead of the cyclopropanethione *S*-oxides.^{5f} Although this is consistent with our result that **2d** is more stable than **1d**, the experimental results are by no means conclusive. The photolysis yield is small

(11) (a) GRADSCF is an ab initio program designed and written by A. Komornicki at Polyatomics Research. (b) Komornicki, A.; Ishida, K.; Morokuma, K.; Ditchfield, R.; Conrad, M. *Chem. Phys. Lett.* **1977**, *45*, 595. (c) McIver, J. W., Jr.; Komornicki, A. *Chem. Phys. Lett.* **1971**, *10*, 202. Pulay, P. *Applications of Electronic Structure Theory*; Schaefer, H. F., III, Ed.; Plenum Press: New York, 1977; p 153. (d) King, H. F.; Komornicki, A. *J. Chem. Phys.* **1986**, *84*, 5465. (e) King, H. F.; Komornicki, A. In *Geometrical Derivatives of Energy Surfaces and Molecular Properties*; Jørgensen, P., Simons, J., Eds.; D. Reidel: Dordrecht, 1986; p 207 (NATO ASI Series C, Vol. 166). (f) Møller, C.; Plesset, M. S. *Phys. Rev.* **1934**, *46*, 618. Pople, J. A.; Binkley, J. S.; Seeger, R. *Int. J. Quantum Chem. Symp.* **1976**, *10*, 1. (g) Dunning, T. H., Jr.; Hay, P. J. In *Methods of Electronic Structure Theory*; Schaefer, H. F., III, Ed.; Plenum Press: New York, 1977; Chapter 1. (f) McLean, A. D.; Chandler, G. S. *J. Chem. Phys.* **1980**, *72*, 5639.

(12) (a) Okiye, K.; Hirose, C.; Lister, D. G.; Sheridan, J. *Chem. Phys. Lett.* **1974**, *24*, 111. (b) Ammon, H. L.; Fallon, L.; Plastas, L. A. *Acta Crystallogr. Sect. B* **1976**, *32*, 2171.

(13) (a) Block, E.; Penn, R. E.; Olsen, R. J.; Sherwin, P. F. *J. Am. Chem. Soc.* **1976**, *98*, 1264. (b) Johnson, D. R.; Powell, F. X.; Kirchhoff, W. H. *J. Mol. Spectrosc.* **1971**, *39*, 136. (c) Block, E.; Bock, H.; Mohmand, S.; Rosmus, P.; Solouki, B. *Angew. Chem., Int. Ed. Engl.* **1976**, *15*, 383. (d) For previous calculations of the structure of sulfene, see: Houk, K. N.; Strozier, R. W.; Hall, J. A. *Tetrahedron Lett.* **1974**, 897. Carlsen, L.; Snyder, J. P. *J. Org. Chem.* **1978**, *43*, 2216.

Table III. Atomic Charges (e)^a

	Compound 1 and Derivative				
	1a ^a	1b ^a	1c ^a	H ₂ CSO ₂	1d ^b
C ₁	-0.13	-0.32	-0.40	-0.57 (-0.17)	-0.55
C ₂	-0.24 (0.06)	-0.20 (0.12)	-0.20 (0.10)		0.23 (0.23)
C ₃	-0.24 (0.06)	-0.24 (0.06)	-0.20 (0.10)		0.18 (0.20)
S	0.02	0.84	1.42	1.42	0.87
O		-0.43	-0.63 ^c	-0.62 ^c	-0.74

	Compound 2			
	2a ^a	2b ^a	2c ^a	2d ^b
C ₁	-0.36 (-0.12)	-0.30 (-0.03)	-0.29 (0.00)	0.30 (0.24)
C ₂	0.09	-0.02	-0.03	-0.25
C ₃	-0.33 (-0.01)	-0.41 (-0.05)	-0.40 (-0.04)	0.01 (-0.03)
S	0.03	0.81	1.37	0.76
O		-0.76	-0.66 ^c	-0.78

^a Value in parentheses is the group charge obtained by adding in the H atom charges. ^b Value in parentheses is the group charge obtained by adding in the two methyl group charges. ^c There are two oxygen atoms.

Table IV. Carbon-13 NMR Chemical Shifts of Cyclopropyl Sulfur Compounds^a

compd	CH ₂ ^b	CHSX or C(Y)SX	CHSO _n X or C(Y)SO _n X	CH ₂ ^c	other
3			42.52 (C)	14.28	-2.37 (Me)
3a ^d			27.09 (C)	10.34	-2.28 (Me)
3b ^d			13.63 (C)	6.04	-2.18 (Me)
5	7.09	30.08			197.67 (C=O); 10.26 (Me)
6	9.67	18.58			
7			40.88	8.36, 4.40	
8			43.14	9.10	
9	8.44 (?)	14.25	38.72	6.45 (?)	
11	13.66	2.90			-3.47 (Me)
12	13.31	16.73			-2.73 (Me)
13	21.24/14.35	33.45/14.64 (C)			-2.36 (Me)
14	20.18	28.84			27.37/13.91 (Et)
18	22.12	45.51 (C)	40.88	7.88	

^a At 75.1 MHz in CDCl₃. ^b Adjacent to CHSX. ^c Adjacent to CHSO_nX. ^d Compound 3a is 1-(trimethylsilyl)cyclopropanesulfonic acid; compound 3b is 1-(trimethylsilyl)cyclopropanesulfinic acid.

and there are other byproducts. Furthermore, the product ratio assumes that the activation energies required to leave the intermediate formed on photolysis are the same for forming 1d or 2d, and this assumption may not be justified.^{5c} Our energy difference is probably good only to $\pm 1-2$ kcal/mol. With the small yield from the photolysis study, it would be difficult to find a very small amount of 1d, especially if the energy difference is at the high end of our error limits.

The dipole moments are also given in Table II together with the predicted ionization potentials. The dipole moments increase with oxygen substitution. For 1a and 2a, the thione 1a has the higher dipole moment. For 1b and 2b, the sulfine 1b has a higher dipole moment although the difference is smaller when compared to the 1a/2a pair. For 1c and 2c, 2c has the higher dipole moment. The ionization potential is also predicted to increase with addition of oxygen to sulfur. The differences between the two isomers also increase with addition of oxygen. The dipole moment of H₂C=SO₂ (3.34 D) is somewhat smaller than in 1c. This is probably due to the fact that the negative charge distribution on carbon in H₂C=SO₂ is spread over more atoms in 1c, effectively giving a longer distance for the charge separation. The HOMO in H₂C=SO₂ (10.98 eV) is somewhat more stable than that in 1c. Methylation of 1b and 2b leads to a significant lowering of the ionization potential, and 2d is predicted to have a lower ionization potential than 1d, in contrast to what is predicted for the 1b/2b pair.

The atomic charges are given in Table III. In 1a, S is essentially neutral with the bonded C negative. Addition of an O (very negative) in 1b makes the S very positive. The C=S bond becomes strongly polarized, with the C becoming more negative as compared to 1a. Addition of a second O to form 1c makes the S more positive, and the SO₂ group becomes more positive leading to an even larger charge at C₁. The behavior of the charges for S, SO, and SO₂ in 2a, 2b, and 2c, respectively, parallels that of

1a, 1b, and 1c. The charges at C₁ and C₂ show an interesting variation with the CH₂ group at C₁ becoming more positive with the addition of oxygen to sulfur and the reverse occurring at C₂.

Methylation of 1b and 2b leads to pronounced changes in the charge distributions for the carbons. In 1d, C₁ becomes more negative whereas the other two carbons become more positive. As seen by the group charges, the methyl groups do not have much charge on them in 1d. The S-O group changes only slightly in 1d. In 2d, the charge on C₁ becomes very positive and the charge on C₂ becomes more negative, leading to a very polar C=C bond. The charge on the other ring carbon does not change significantly. The charges on the methyl hydrogens do show one novel feature. The charges on all of the hydrogens are 0.10-0.13 e except for the charge on the hydrogen closest to the oxygen. The charge on this hydrogen increased by 0.17 e. The distance between this hydrogen and the O is short, 2.58 Å. The above results suggest that there is a significant interaction between the hydrogen and the negative oxygen, which leads to a significant polarization of the charge on the hydrogen. Clearly the substituents are not just affecting the ring carbons.

Preparation of Starting Materials. Various derivatives of cyclopropanethiol and 1-(trimethylsilyl)cyclopropanethiol were prepared by straightforward adaption of literature methods^{4c,14} as summarized in Scheme IV. Carbon-13 NMR chemical shifts for these new compounds are given in Table IV. Cyclopropanethiol¹⁵ (4), prepared through reaction of cyclopropylmagnesium bromide with sulfur, was converted to the corresponding thioacetate 5 with acetyl chloride or to disulfide 6 with iodine. Chlorination of 5 or 6 in acetic anhydride at -10 to -20 °C gave cyclopropanesulfinyl chloride (7, 73-76%); chlorination

(14) Douglas, I. B.; Norton, R. V. *J. Org. Chem.* 1968, 33, 2104.

(15) (a) Knight, A. R.; Strausz, O. P.; Gunning, H. E. *J. Am. Chem. Soc.* 1963, 85, 1207. (b) Brandsma, L. *Recl. Trav. Chim. Pays-Bas* 1970, 89, 593.

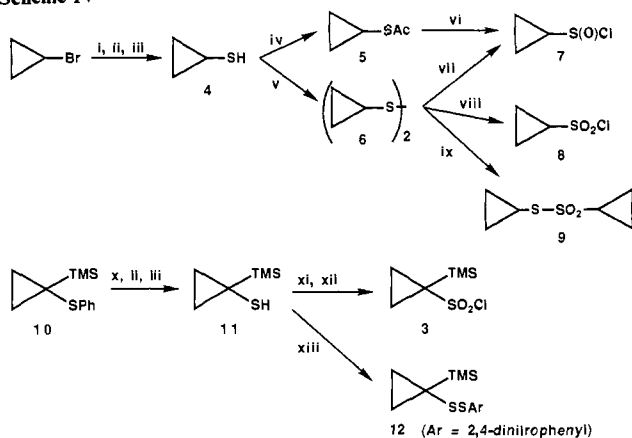
Scheme IV^a

^a(i) Mg/THF; (ii) S₈; (iii) LiAlH₄, H⁺; (iv) AcCl; (v) I₂; (vi) SO₂Cl₂/Ac₂O; (vii) Cl₂/Ac₂O; (viii) excess Cl₂/Ac₂O; (ix) MCPBA; (x) Li, DMAN; (xi) CH₃CO₃H; (xii) SOCl₂; (xiii) ArSCl.

Scheme V

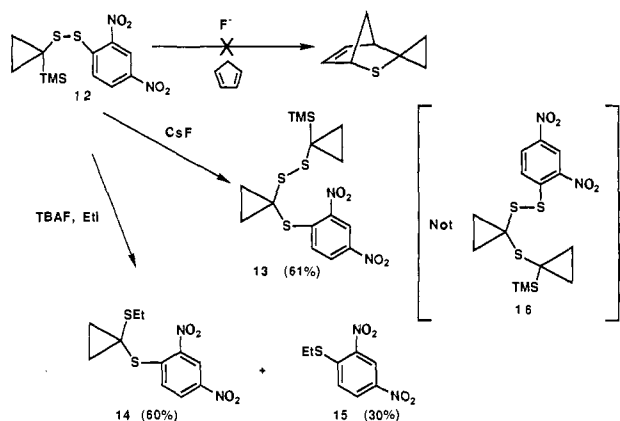

of **6** with excess chlorine at 5 °C gave cyclopropanesulfonyl chloride (**8**, 71%), and MCPBA oxidation of **6** gave *S*-cyclopropyl cyclopropanethiosulfonate (**9**). 1-(Trimethylsilyl)cyclopropyl phenyl sulfide^{16a} (**10**) was converted by reductive lithiation^{16b} followed by sulfuration to 1-(trimethylsilyl)cyclopropanethiol (**11**, 41%), which in turn was transformed by oxidation followed by chlorination into 1-(trimethylsilyl)cyclopropanesulfonyl chloride (**3**, 57%).

Approaches to Cyclopropanethione. On the basis of precedent in the work of Krafft,^{3a} we sought a low-temperature route to cyclopropanethione (**1a**). Thus, 1-(trimethylsilyl)cyclopropyl 2,4-dinitrophenyl disulfide (**12**), prepared in 82% yield from reaction of thiol **10** with 2,4-dinitrobenzenesulfonyl chloride in ether, was desilylated at -20 °C with CsF in the presence of excess 1,3-cyclopentadiene. However, the only product isolated was 1-[(2,4-dinitrophenyl)thio]cyclopropyl 1-(trimethylsilyl)cyclopropyl disulfide (**13**, 61%). There was no indication from GC-MS analysis of the presence of the cyclopentadiene adducts of **1a** or **2a**. Similar results were obtained using 2,3-dimethyl-1,3-butadiene. When the desilylation was repeated with excess ethyl iodide/tetrabutylammonium fluoride (TBAF) instead of diene/CsF, the products consisted of 1-[(2,4-dinitrophenyl)thio]-1-(ethylthio)cyclopropane (**14**, 60%) and 2,4-dinitrophenyl ethyl sulfide (**15**, 30%) (Scheme V). Significant quantities of other low molecular weight products could not be detected by GC-MS analysis. Treatment of **12** with a mixture of excess 2,3-dimethyl-1,3-butadiene, ethyl iodide, and TBAF afforded only **14** (63% yield), supporting the assignment of **13** as 1-[(2,4-dinitrophenyl)thio]cyclopropyl 1-(trimethylsilyl)cyclopropyl disulfide

Scheme VI

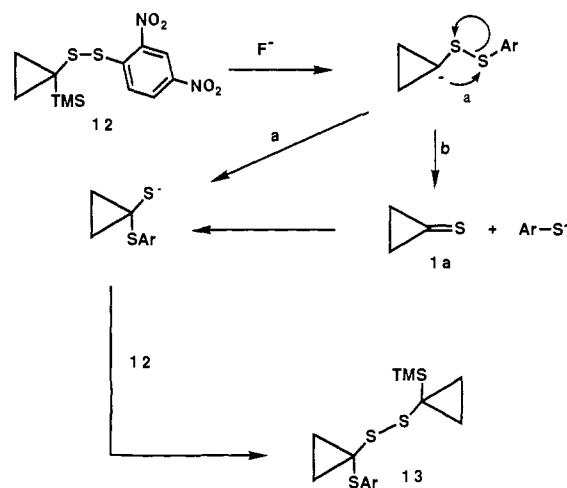

Scheme VII

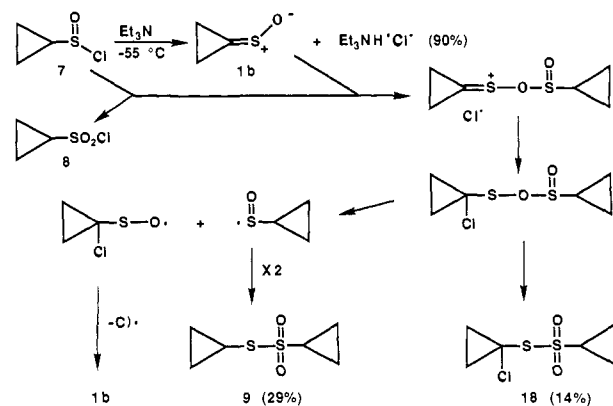

rather than 1-[(1-(trimethylsilyl)cyclopropyl)thio]cyclopropyl 2,4-dinitrophenyl disulfide (**16**). Substitution of 1-(trimethylsilyl)cyclopropyl 2-nitrophenyl disulfide (**17**) for **12** in the above experiments led to similar results.^{17a} These experiments are consistent with intramolecular rearrangement of an arylthio α -cyclopropyl carbanion (Scheme VI, path a) to 1-[(2,4-dinitrophenyl)thio]cyclopropanethiolate followed by displacement at sulfur in **12** or on carbon in ethyl iodide, giving **14** or **15**, respectively. Related rearrangements of disulfides are known.^{17b} Fluorodesilylation of other (trimethylsilyl)cyclopropyl systems has been shown to stop at carbanion formation rather than fragmentation, affording strained compounds with exocyclic double bonds.^{18a,b} A mechanism involving fragmentation to cyclopropanethione (**1a**) (Scheme VI, path b) is considered unlikely in view of the absence of even minor quantities of Diels-Alder adducts when fluorodesilylation is conducted in the presence of dienes.^{18c}

Other unsuccessful approaches to **1a** include treatment of 1-(trimethylsilyl)cyclopropanesulfonyl chloride with TBAF in the presence of cyclopentadiene, treatment of cyclopropanesulfonyl chloride with Et₃N in the presence of cyclopentadiene, photolysis of 1-(cyclopropylthio)-3-phenyl-2-propanone (c-C₃H₅SCH₂C(O)Ph) in the presence of 1,3-dienes,^{3b} and treatment of tri-

(16) (a) Paquette, L. A.; Wells, G. J.; Horn, F. A.; Yan, T. H. *Tetrahedron* **1983**, *39*, 913. (b) Cohen, T.; Sherbine, J. P.; Matz, J. R.; Hutchins, R. R.; McHenry, B. M.; Wiley, P. R. *J. Am. Chem. Soc.* **1984**, *106*, 3245.

(17) (a) Treatment of **17** with CsF afforded 1-[(2-nitrophenyl)thio]cyclopropyl 1-(trimethylsilyl)cyclopropyl disulfide, which gave **11** upon LiAlH₄ reduction. Treatment of **17** with CsF/EtI gave 1-[(2-nitrophenyl)thio]-1-(ethylthio)cyclopropane, which was shown to be different from authentic 1-ethyl-1-cyclopropyl 2-nitrophenyl disulfide prepared from 1-ethyl-1-cyclopropanethiol. (b) Danehy, J. P. *Int. J. Sulfur Chem. B* **1971**, *6*, 103 and references therein.

(18) (a) Lillya, C. P.; Sassi, T. P. *Tetrahedron Lett.* **1989**, *30*, 6133. (b) Padwa, A.; Wannamaker, M. W.; Dyszewski, A. D. *J. Org. Chem.* **1987**, *52*, 4760. (c) Kirby, G. W.; Lochead, A. W.; Sheldrake, G. N. *J. Chem. Soc., Chem. Commun.* **1984**, 1469.

phenylphosphonium cyclopropanide with S_8 in the presence of 1,3-dienes. Curiously, in the latter case Diels–Alder adducts of S_n ($n = 2-4$) were isolated.

Approaches to Cyclopropanethione *S*-Oxide. Treatment of sulfinyl chloride **7**, prepared as shown in Scheme IV, with triethylamine led to the immediate precipitation of triethylamine hydrochloride in 90% yield along with *S*-1-chlorocyclopropyl cyclopropanethiosulfonate (**18**, 14%), *S*-cyclopropyl cyclopropanethiosulfonate (**9**, 29%), and cyclopropanesulfonyl chloride (**8**, 21%) as the major volatile products (Scheme VII). Compound **18** was characterized by comparing its spectroscopic and chromatographic properties with those of an authentic sample of **9** (e.g., see Table IV for comparative ^{13}C NMR data). Scheme VII rationalizes formation of the various products via the intermediacy of cyclopropanethione *S*-oxide (**1b**). These types of reactions have previously been reported as establishing the intermediacy of sulfines.¹⁹ We were unsuccessful in intercepting **1b** when **7** was treated with triethylamine or when 1-(trimethylsilyl)cyclopropanesulfonyl chloride²⁰ was treated with fluoride ion in the presence of dienes such as cyclopentadiene, 2,3-dimethylbutadiene, or 1,2-dimethylenecyclohexane.

Approaches to Cyclopropanethione *S,S*-Dioxide. 1-(Trimethylsilyl)cyclopropanesulfonyl chloride (**3**) could be prepared in 23% overall yield from the known 1-(trimethylsilyl)cyclopropyl phenyl sulfide (**10**)¹⁵ as shown in Scheme IV. Treatment of **3** with CsF in acetonitrile at room temperature for 3 h in the presence of excess 1-(*N,N*-diethylamino)-1-propyne led to the isolation of 4-(*N,N*-diethylamino)-3-methyl-2-thiaspiro[3.2]hex-3-ene 2,2-dioxide (**19**) as a colorless crystalline solid, mp 123–123.5 °C, in 56% yield (eq 2). Spectroscopic data (^1H and ^{13}C NMR,

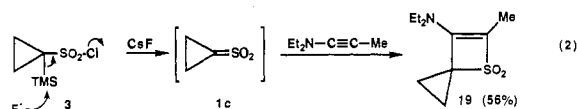

IR) for **19** is in good agreement with that for known sulfene adducts. This experiment provides the first direct evidence for the formation and trapping of cyclopropanethione *S,S*-dioxide (**1c**). While reaction of **3** with 1-morpholinocyclohexane/CsF at 0 °C gave the expected adduct in low yield, we were unsuccessful in trapping **1c** generated from **3** in the presence of thiobenzophenone, 1,1-dithoxyethene, 1,3-cyclopentadiene, 2,3-dimethylbutadiene, diphenylisobenzofuran, or ethoxyacetylene. Attempts to prepare **19** via reaction of excess 1-(*N,N*-diethylamino)-1-propyne with cyclopropanesulfonyl chloride (**8**) and triethylamine were unsuccessful. Compound **8** was consumed, but no cyclopropyl-containing products were isolated from the mixture. It is likely that **1c** is formed¹⁰ but reacts more rapidly with triethylamine than with 1-(*N,N*-diethylamino)-1-propyne.

Conclusion

Evidence is presented for the trapping of cyclopropanethione *S*-oxide (**1b**) and *S,S*-dioxide (**1c**). The considerable utility of the fluorodesilylation route to sulfenes^{4a-c} is further established. Our own inability, and that of others, to trap cyclopropanethione (**1a**) itself makes us pessimistic that it will be possible to catch this thermodynamically unstable molecule. Perhaps the best hope lies in the preparation of derivatives of **1a** in which the cyclopropane ring has been modified in such a way so as to decrease the stability of the **2a** form relative to the **1a** form, e.g., dispiro[2.0.2.1]heptane-7-thione (**20**, eq 3). In this case we find the

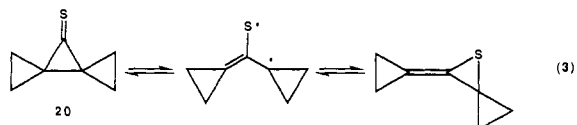

(19) (a) Block, E.; Bazzi, A. A. *Tetrahedron Lett.* **1982**, 23, 4569. (b) Freeman, F.; Keindl, M. C. *J. Org. Chem.* **1988**, 53, 2026.

(20) Prepared by oxidizing thiol **11** with 2 equiv of MCPBA to 1-(trimethylsilyl)cyclopropanesulfinic acid (**3b**) followed by treatment with SOCl_2 . The chloride was obtained 80–90% pure (*m*-chlorobenzoyl chloride was impurity).

energy difference at the MP-2 level between the optimized structures for **20** and its thiirane valence tautomer to be 2.4 kcal/mol, favoring structure **20**.

Experimental Section

Cyclopropanethiol (4).¹⁵ Cyclopropylmagnesium bromide was prepared by slow addition of cyclopropyl bromide (11.89 g, 98.3 mmol) in THF (40 mL) to Mg (2.27 g, 93.4 mmol) suspended in THF (5 mL) at 0 °C. The solution was then warmed to 50 °C for 3 h and then cooled to 0 °C, at which time solid S_8 (2.47 g, 77.0 mmol) was added in small portions. Once addition was complete, the mixture was heated to 50 °C for 3 h and then cooled to 0 °C. Solid LiAlH_4 (2.0 g, 52.8 mmol) was added in portions and the solution was refluxed for 0.5 h. To the chilled (0 °C) solution were added (slowly) H_2O (3 mL), 5% aqueous H_2SO_4 (20 mL), and ether (50 mL). The layers were separated, the aqueous layer was extracted with ether (50 mL), the combined ether extract was washed with 5% aqueous H_2SO_4 (1 × 20 mL), 5% aqueous Na_2CO_3 (10 × 15 mL), saturated NH_4Cl (1 × 20 mL), and brine, dried (MgSO_4), and filtered, affording an ether/THF solution of cyclopropanethiol (**4**) in 30–45% conversion from cyclopropyl bromide.

Dicyclopropyl Disulfide (6). To an ether/THF solution of cyclopropanethiol (**4**; from 119 mmol of cyclopropyl bromide) was added a solution of NaOEt (1.81 g of Na, 78.7 mmol) in EtOH (100 mL). To this thiolate solution was added solid I_2 (20.0 g, 78.0 mmol) in small portions. After stirring at room temperature for 0.5 h, the reaction was quenched with saturated aqueous NaHSO_3 (50 mL), brine (100 mL), and ether (100 mL). The layers were separated, and the organic layer was washed with H_2O (6 × 50 mL) and brine and then was dried over MgSO_4 . Filtration, concentration (aspirator), and distillation yielded dicyclopropyl disulfide (2.77 g, 38% from cyclopropyl bromide) as a clear, foul-smelling liquid: bp 40–41 °C, 0.4 mm; ^1H NMR δ 2.25 (m, 1 H), 0.92 (m, 2 H), 0.69 (m, 2 H); ^{13}C NMR δ 18.58 (CH), 9.67 (CH₂); IR (film) 3081, 3006, 1446, 1422, 1271, 1189, 1048, 1023, 870, 820 cm^{-1} ; GC–MS *m/e* (%) 146 (M^+ , 60), 105 (40), 86 (44), 85 (100), 79 (21), 74 (27), 73 (99), 72 (29), 71 (51), 61 (33), 59 (31), 58 (32).

***S*-Cyclopropyl Thioacetate (5).** To an ether/THF solution of cyclopropanethiol (**4**; from 117 mmol of cyclopropyl bromide) were added oven-dried Na_2CO_3 (51 g, 480 mmol) and acetyl chloride (11.5 g, 147 mmol). The solution was stirred vigorously at room temperature for 18 h, at which time the mixture was filtered through Celite and concentrated (aspirator). Distillation of the residue provided **5** (3.39 g, 25% based on cyclopropyl bromide) as a colorless, foul-smelling liquid: bp 42 °C, 20 mm; ^1H NMR δ 2.24 (s, 3 H), 2.08 (m, 1 H), 1.00 (m, 2 H), 0.51 (m, 2 H); ^{13}C NMR δ 197.67, 30.08 (CH), 10.26 (CH₃), 7.09 (CH₂); IR (film) 3011, 1698 (vs), 1425, 1354, 1284, 1136, 1110, 1029, 956, 622 cm^{-1} ; GC–MS *m/e* (%) 116 (M^+ , 16), 74 (100), 73 (15), 71 (10), 59 (13), 58 (18).

Cyclopropanesulfonyl Chloride (7). **Method A.** A dry 3-necked round-bottom flask was charged with dicyclopropyl disulfide (**6**; 4.09 g, 28.0 mmol) and acetic anhydride (5.71 g, 56.0 mmol). The flask and contents were cooled to –20 °C, and the mixture was treated with Cl_2 as described previously.¹⁴ Care was taken to ensure that the temperature of the reaction mixture did not exceed –10 °C. The chlorination was followed gravimetrically and by ^1H NMR spectroscopy (acetyl Me shifts for Ac_2O vs AcCl) to completion. The acetyl chloride was distilled off followed by **7** (5.08 g, 73%), obtained as a pungent liquid: bp 28–29 °C, 1 mm; ^1H NMR δ 3.02 (m, 1 H), 1.57 (m, 1 H), 1.34–1.13 (m, 3 H); ^{13}C NMR δ 40.88 (CH), 8.36 (CH₂), 4.40 (CH₂); IR (film) 3047, 3012, 1148 (vs), 1035, 874 cm^{-1} ; GC–MS *m/e* (%) 105 (($\text{M} - \text{Cl}$)⁺, 100), 99 (11), 83 (12), 76 (16), 65 (10), 64 (76), 57 (9).

Method B. Based on work reported previously,^{4c} a stirred solution of *S*-cyclopropyl thioacetate (**5**, 2.56 g, 22.1 mmol) and acetic anhydride (2.25 g, 22.1 mmol) was cooled to –10 °C. Sulfonyl chloride (5.94 g, 44.0 mmol) was added dropwise over a period of 45 min, and the solution was stirred for 45 min more at this temperature. The flask was then fitted with a distillation apparatus, and the acetyl chloride was removed under reduced pressure followed by cyclopropanesulfonyl chloride (**7**, 2.10 g, 76%).

Generation of Cyclopropanethione *S*-Oxide (1b**) in the Presence of **7**.** A mixture of freshly distilled **7** (0.125 g, 1 mmol) and ether (10 mL) was cooled in a dry round-bottomed flask under argon to –55 °C. Triethylamine (100 μL , 0.71 mmol) was slowly added to the stirred solution, resulting in the immediate formation of a white precipitate. The resulting suspension was stirred at –55 °C for 2 h and then slowly warmed to room temperature and stirred for 40 h. Analysis of the crude mixture by GC–MS and GC using undecane as internal standard showed cyclopropanesulfonyl chloride (**8**, 21%), *S*-cyclopropyl cyclopropanethiosulfonate (**9**, 29%), and *S*-1-chlorocyclopropyl cyclopropanethiosulfonate (**18**, 14%) as the major volatile products. After filtration and drying, triethylamine hydrochloride was isolated (87 mg, 90% yield). Column

chromatography of the filtrate (ether/hexanes 1/3) afforded **18** ($R_f = 0.36$) and **9** both in low yield. Spectral data for **18**: $^1\text{H NMR } \delta$ 3.12 (m, 1 H), 1.78 (m, 2 H), 1.69 (m, 2 H), 1.50 (m, 2 H), 1.23 (m, 2 H); $^{13}\text{C NMR } \delta$ 45.51 (C), 40.88 (CH), 22.12 (CH₂), 7.88 (CH₂); IR (film) 2926, 2855, 1420, 1331 (vs), 1294, 1261, 1187, 1139, 1123 (vs), 1040, 875, 712, 688 cm⁻¹; GC-MS m/e (%) 109 ((M - 105)⁺ for ^{35}Cl , 38), 107 ((M - 105)⁺ for ^{35}Cl , 100), 81 (20), 79 (54), 73 (16), 72 (43), 71 (48).

S-Cyclopropyl Cyclopropanethiosulfonate (9). Dicyclopropyl disulfide (6, 490 mg, 3.36 mmol) in CH₂Cl₂ (20 mL) was cooled to -78 °C. Solid MCPBA (82%, 1.4 g, 6.65 mmol) was added in small portions. After removal of the cold bath, stirring was continued for 4 h. The mixture was then cooled to 0 °C and filtered. The filtrate was washed with saturated aqueous Na₂CO₃ (3 × 30 mL) and brine and then dried over MgSO₄. After filtration and concentration, flash chromatography (25% ether in hexane) gave **9** (400 mg, 62%) as a colorless oil: $R_f = 0.16$ (5% ether); $^1\text{H NMR } \delta$ 2.95 (m, 1 H), 2.48 (m, 1 H), 1.37 (m, 2 H), 1.17 (m, 4 H), 0.95 (m, 2 H); $^{13}\text{C NMR } \delta$ 38.72 (CH), 14.25 (CH), 8.44 (CH₂), 6.45 (CH₂); IR (film) 1322 (vs), 1296, 1129 (vs), 1035, 878, 690 cm⁻¹; GC-MS m/e (%) 178 (M⁺, 1), 89 (7), 73 (100), 72 (16), 75 (8).

1-(Trimethylsilyl)cyclopropanethiol (11). 1-Lithio-1-(trimethylsilyl)cyclopropane was prepared in THF (40 mL) from 1-(trimethylsilyl)cyclopropyl phenyl sulfide¹⁵ (10, 3.60 g, 16.2 mmol), lithium (293 mg, 42.2 mmol), and 1-(dimethylamino)naphthalene (7.20 g, 42.0 mmol) according to Cohen.¹⁶ Elemental sulfur (860 mg, 26.9 mmol) was added, and the solution was warmed to 25 °C with stirring for 16 h. The flask was fitted with a reflux condenser and was immersed in an ice-water bath. Solid LiAlH₄ (1.00 g, 26.4 mmol) was added in small portions. Once addition was complete the contents were refluxed for 8 h. To the chilled (0 °C) solution were added (slowly!) H₂O (3 mL), 5% aqueous H₂SO₄ (20 mL), and ether (50 mL). The layers were separated, the aqueous layer was extracted with ether (50 mL), the combined ether extract was washed with 5% aqueous H₂SO₄ (1 × 20 mL), 5% aqueous Na₂CO₃ (10 × 15 mL), saturated NH₄Cl (1 × 20 mL), and brine, dried (MgSO₄), filtered, concentrated, and distilled to yield title compound **11** (980 mg, 41%), bp 37–38 °C (10 mm), which solidified in the cooled distillation receiver giving a colorless solid: mp 26–27 °C; $^1\text{H NMR } \delta$ 1.89 (s, 1 H, SH), 0.78–0.71 (m, 4 H), 0.03 (s, 9 H); $^{13}\text{C NMR } \delta$ 13.66 (CH₂), 2.90 (C), -3.47 (CH₃); IR (film) 3072, 2996, 2956, 2899, 2561 (vw), 1427, 1249, 1229, 1027 (m), 920, 885 (vs) cm⁻¹; GC-MS m/e (%) 146 (4, M⁺), 131 (5), 91 (44), 90 (7), 75 (17), 74 (8), 73 (100).

1-(Trimethylsilyl)cyclopropanesulfonyl Chloride (3). Peracetic acid (10 mL, 35%) was added to a stirred solution of 1-(trimethylsilyl)cyclopropanethiol (**11**) (640 mg, 4.28 mmol) in acetic acid (8 mL). The solution was heated at 60 °C for 2.5 h and then concentrated in vacuo, affording 1-(trimethylsilyl)cyclopropanesulfonic acid as a colorless semisolid which was used directly in the next step: $^1\text{H NMR } \delta$ 10.91 (s, br, 1 H), 1.37 (m, 2 H), 0.92 (m, 2 H), 0.16 (s, 9 H); $^{13}\text{C NMR } \delta$ 27.09 (C), 10.34 (CH₂), -2.28 (CH₃); IR (film) 3399 (br), 2958, 2798 (br), 2229 (br), 1732 (br), 1251, 1231, 1181, 1133 (br), 1049, 1016, 925, 843 (vs), 756 cm⁻¹. Thionyl chloride (4 mL) was added dropwise with stirring to the semisolid at -78 °C, and stirring was continued as the mixture warmed to 25 °C over 5 h. Excess thionyl chloride was removed under vacuum, and the residue was taken up in CH₂Cl₂ (5 mL), transferred to a smaller flask, concentrated, and then flash distilled to give the title compound **3** as a clear oil (530 mg, 57% from the thiol): bp 32 °C (0.005 mm); $^1\text{H NMR } \delta$ 1.75 (m, 2 H), 1.22 (m, 2 H), 0.26 (s, 9 H); $^{13}\text{C NMR } \delta$ 42.52 (C), 14.28 (CH₂), -2.37 (CH₃); IR (film) 2962, 1357 (vs), 1256, 1180 (vs), 1138, 1044, 916, 848 (vs), 742 cm⁻¹; GC-MS m/e (%) 197 ((M - 15)⁺ for ^{35}Cl , 7), 95 (35), 94 (8), 93 (100), 73 (50), 58 (9).

4-(N,N-Diethylamino)-3-methyl-2-thiaspiro[3.2]hex-3-ene 2,2-Dioxide (19). A 3-necked flask equipped with a stir bar was charged with CsF (236 mg, 1.55 mmol). The flask was flame-dried under vacuum and allowed to cool under argon. After acetonitrile (3 mL) and 1-(N,N-diethylamino)-1-propyne (340 mg, 2.88 mmol) were added, **3** (319 mg, 1.50 mmol) in acetonitrile (3.5 mL) was added dropwise over 5 min. After the mixture was stirred for 3 h at 25 °C, 8 volumes of ether were added. The mixture was filtered, concentrated, and subjected to flash chromatography with 40% EtOAc in hexanes as eluant. The fraction with $R_f = 0.17$ (50% EtOAc in hexane) was concentrated to give **19** (179 mg, 56%). An analytical sample prepared by recrystallization from pentane/EtOAc had the following spectral data: mp 123–123.5 °C; $^1\text{H NMR } \delta$ 3.02 (q, 4 H, $J = 7$ Hz), 2.02 (s, 3 H), 1.54 (m, 2 H), 1.45 (m, 2 H), 1.18 (t, 6 H, $J = 7$ Hz); $^{13}\text{C NMR } \delta$ 146.37 (olefinic α to N), 110.52 (olefinic α to S), 59.08 (Δ C), 43.80 (Et CH₂), 14.13 (Et CH₃), 9.19 (Δ CH₂), 7.83 (CH₃); IR (film) 2970, 1628 (vs), 1434, 1261 (vs), 1202, 1156, 1138, 1092 (vs), 1022, 199, 751 cm⁻¹; GC-MS m/e (%) 215 (61), 136 (47), 122 (54), 108 (26), 96 (42), 95 (66), 94 (60), 79 (31), 77 (41), 68 (27), 67 (100), 66 (39), 65 (24), 56 (39), 55 (21), 54 (34), 53 (36), 52 (25), 51 (24). Anal. Calcd for C₁₀H₁₇SNO₂: C, 55.78; H, 7.96. Found: C, 55.95; H, 8.20.

Cyclopropanesulfonyl Chloride (8). A 3-necked round-bottom flask was charged with cyclopropyl disulfide (6, 2.94 g, 20 mmol) and acetic anhydride (8.16 g, 80 mmol). The flask was cooled to -20 °C, and the mixture was saturated with Cl₂ and was then allowed to stand at 5 °C for 12 h. The Cl₂ saturation procedure was repeated and the mixture was allowed to stand at 5 °C overnight. Distillation afforded acetyl chloride followed by the title compound **8** (3.99 g, 71%); bp 31–33 °C (0.07 mm); $^1\text{H NMR } \delta$ 3.29 (m, 1 H), 1.60 (m, 2 H), 1.36 (m, 2 H); $^{13}\text{C NMR } \delta$ 43.14 (CH), 9.10 (CH₂); IR (film) 3064, 1369 (vs), 1163 (vs), 877, 693 cm⁻¹; GC-MS m/e (%) 105 ((M - Cl)⁺, 100), 99 (12), 83 (11), 76 (15), 64 (64).

Reaction of Cyclopropanesulfonyl Chloride (8) with Triethylamine in the Presence of 1-(N,N-Diethylamino)-1-propyne. Cyclopropanesulfonyl chloride (**8**, 263 mg, 1.87 mmol) in CH₂Cl₂ (3.5 mL) was added via syringe to a stirred, ice-cooled solution of 1-(N,N-diethylamino)-1-propyne (400 mg, 3.60 mmol), Et₃N (358 mg, 3.54 mmol), and CH₂Cl₂ (3 mL). The mixture was allowed to stir and warm to 25 °C over 12 h. The mixture was diluted with 5 volumes of ether, filtered, and concentrated. Analysis by GC provided no evidence for the formation of **19**.

1-(Trimethylsilyl)cyclopropyl 2,4-Dinitrophenyl Disulfide (12). To a stirred solution of **11** (600 mg, 4.11 mmol) in dry ether (30 mL) was added solid 2,4-dinitrobenzenesulfonyl chloride (1.150 g, 4.90 mmol) in small portions. After the mixture was stirred for 12 h at 25 °C, ether (30 mL) was added, and the solution was washed with saturated aqueous Na₂CO₃ (3 × 30 mL) and brine, dried (MgSO₄), filtered, and concentrated. Flash chromatography (2% EtOAc in hexane) followed by recrystallization from pentane yielded the title compound **12** as yellow crystals (1.16 g, 82%); mp 99.5–100 °C (from pentane); $^1\text{H NMR } \delta$ 9.03 (d, 1 H, $J = 2.7$ Hz), 8.45 (d, 1 H, $J = 9.4$ Hz), 8.42 (dd, 1 H, $J = 9.4, 2.7$ Hz), 0.93–0.83 (m, 4 H), 0.07 (s, 9 H); $^{13}\text{C NMR } \delta$ 147.60, 145.23, 144.90, 129.19, 126.83, 121.00, 16.73 (C), 13.31 (CH₂), -2.73 (CH₃); IR (Nujol) 1587, 1508, 1337, 1304, 1244, 1028, 912, 897, 832 cm⁻¹; GC-MS m/e (%) 344 (M⁺, 2), 177 (8), 117 (6), 91 (7), 75 (13), 74 (10), 73 (100), 71 (9).

Desilylation of 12 in the Presence of Dienes. Formation of 1-[(2,4-Dinitrophenyl)thio]cyclopropyl 1-(Trimethylsilyl)cyclopropyl Disulfide (13). A flask containing a stir bar and CsF (208 mg, mmol) was flame-dried, and after it was cooled under argon, MeCN (15 mL) and a diene (cyclopentadiene or 2,3-dimethylbutadiene; 2 mL) were added. This mixture was stirred at -20 °C while **12** (400 mg, 1.16 mmol) in MeCN (15 mL) was added over a period 15 min. After 5 h of stirring and warming to 25 °C, the reaction mixture was extracted with pentane (2 × 20 mL). The pentane solution was concentrated. Analysis by GC and GC-MS gave no evidence for the presence of cyclopropanethione or allene episulfide Diels-Alder adducts. Chromatography (Chromatotron) of the residue (5% EtOAc in hexanes) yielded varying amounts of **12** (40–90 mg) and **13** (110–186 mg, 61–86% based on consumed starting material): mp 113.5–114.5 °C (EtOAc/pentane); $R_f = 0.31$ (8/1 hexanes/EtOAc); $^1\text{H NMR } \delta$ 9.08 (d, 1 H, $J = 2.5$ Hz), 8.45 (dd, 1 H, $J = 2.5, 9.2$ Hz), 8.12 (dd, 1 H, $J = 9.2$ Hz), 1.69 (m, 2 H), 1.51 (m, 2 H), 0.96 (m, 2 H), 0.85 (m, 2 H), 0.01 (s, 9 H); $^{13}\text{C NMR } \delta$ 146.12, 144.37, 144.29, 129.03, 126.90, 121.54, 33.45 (C), 21.24 (CH₂), 14.64 (C), 14.35 (CH₂), -2.36 (CH₃); IR (film) 3110, 2956, 1595, 1524, 1340, 1303, 1249, 1130, 1051, 901, 841, 745, 735, cm⁻¹; GC-MS m/e (%) 271 ((M - 145)⁺, 20), 183 (20), 177 (27), 137 (8), 123 (8), 117 (7), 75 (12), 74 (9), 73 (100), 72 (9), 71 (15), 5 (8). Anal. Calcd for C₁₅H₂₀S₂SiN₂O₄: C, 43.25; H, 4.83. Found: C, 43.18; H, 4.86.

Desilylation of 12 with TBAF in the Presence of EtI. A flame-dried 3-neck round-bottom flask is charged with MeCN (10 mL), EtI (3 mL, distilled from Na), and **12** (250 mg, 0.727 mmol). The mixture was stirred at room temperature, and TBAF (2.0 equiv, ~1.0 M in MeCN) was added quickly via syringe. After 60 h of stirring, the mixture was passed through a minicolumn of silica gel, and the solvent was removed. The residue was taken up in ether, filtered, concentrated, and chromatographed (Chromatotron), affording 1-[(2,4-dinitrophenyl)thio]-1-(ethylthio)cyclopropane (**14**) (130 mg, 60%), mp 92–94 °C, $R_f = 0.11$ (5% EtOAc), and 2,4-dinitrophenyl ethyl sulfide²¹ (**15**) (50 mg, 30%). Spectral data for **14**: $^1\text{H NMR } \delta$ 9.10 (d, 1 H, $J = 2.5$ Hz), 8.46 (dd, 1 H, $J = 9.2, 2.5$ Hz), 8.19 (d, 1 H, $J = 9.2$ Hz), 2.84 (q, 2 H, $J = 7.2$ Hz), 1.55 (m, 2 H), 1.46 (m, 2 H), 1.29 (t, 3 H, $J = 7.2$ Hz); $^{13}\text{C NMR } \delta$ 146.30, 144.52, 144.20, 129.43, 126.83, 121.51, 28.84 (C), 27.37 (Et CH₂), 20.18 (Δ CH₂), 13.91 (CH₃); IR (film) 3091, 2969, 2928, 2870, 1595, 1520, 1339, 1304, 1132, 1093, 1051, 916, 832, 746, 735 cm⁻¹; GC-MS m/e (%) 300 (M⁺, 0.2), 271 ((M - Et)⁺, 5), 254 (100), 226 (14), 192 (8), 137 (16), 136 (8), 105 (10), 101 (22), 95 (12), 75 (25), 73 (65), 71 (55), 67 (20). Compound **15**: mp 112.5–113 °C (pentane-

(21) Buckingham, J., Ed. *Dictionary of Organic Compounds*, 6th ed.; Chapman & Hall: New York, 1982; Vol. 2, p 2256.

/EtOAc) (lit. mp 113 °C);²¹ ¹H NMR δ 9.04 (d, 1 H, *J* = 2.4 Hz), 8.36 (dd, 1 H, *J* = 2.4, 8.7 Hz), 7.57 (d, 1 H, *J* = 8.7 Hz), 3.08 (q, 2 H, *J* = 7.3 Hz), 1.46 (t, 3 H, *J* = 7.3 Hz); ¹³C NMR δ 147.29, 144.59, 143.60, 126.98, 126.75, 121.65, 26.71, 12.44; IR (film) 3098, 2986, 1589, 1516, 1451, 1344, 1308, 1246, 154, 1098, 1053, 921, 832, 734 cm⁻¹; GC-MS *m/e* (%) 228 (M⁺, 59), 200 (16), 184 (30), 183 (100), 137 (16), 106 (20), 95 (28), 91 (17), 79 (28), 77 (16), 69 (38), 63 (52), 62 (16).

Acknowledgment. We thank Shu Hai Zhao and Mohan Thiruvazhi for experimental assistance and gratefully acknowledge support from the donors of the Petroleum Research Fund, ad-

ministered by the American Chemical Society, the Herman Frasch Foundation, the National Science Foundation, and Société Nationale Elf Aquitaine.

Registry No. 1a, 81788-92-3; 1b, 139631-56-4; 1c, 139631-57-5; 1d, 139631-59-7; 2a, 64251-85-0; 2b, 33945-99-2; 2c, 139631-58-6; 2d, 76832-59-2; 3, 139631-66-6; 3a, 139631-71-3; 3b, 139631-72-4; 4, 6863-32-7; 5, 139631-60-0; 6, 68846-57-1; 7, 139631-61-1; 8, 139631-62-2; 9, 139631-63-3; 10, 74379-74-1; 11, 139631-65-5; 12, 139631-68-8; 13, 139631-69-9; 14, 139631-70-2; 15, 7343-55-7; 18, 139631-64-4; 19, 139631-67-7; sulfene, 917-73-7; bromocyclopropane, 4333-56-6.

¹³C–¹³C Spin Coupling Constants in Aldoses Enriched with ¹³C at the Terminal Hydroxymethyl Carbon: Effect of Coupling Pathway Structure on *J*_{CC} in Carbohydrates

Jian Wu,[†] Paul B. Bondo,[‡] Tapani Vuorinen,[§] and Anthony S. Serianni^{*†}

Contribution from the Department of Chemistry and Biochemistry, University of Notre Dame, Notre Dame, Indiana 46556, Omicron Biochemicals, Inc., 19882 Alou Lane, South Bend, Indiana 46637, and Laboratory of Wood Chemistry, Helsinki University of Technology, SF-02150 Espoo, Finland. Received July 31, 1991

Abstract: Eight aldohexoses (allo, altro, galacto, gluco, gulo, ido, manno, talo), four aldopentoses (arabino, lyxo, ribo, xylo), and two aldotetroses (erythro, threo) have been prepared with ¹³C-enrichment (99 atom-% ¹³C) at the terminal hydroxymethyl (CH₂OH) carbon. High-resolution ¹H-decoupled ¹³C NMR spectra were obtained at 75 and 125 MHz in order to obtain one-bond (¹*J*_{CC}) and longer range (²*J*_{CC}, ³*J*_{CC}) ¹³C–¹³C spin coupling constants involving the terminal carbons of the more abundant furanose and pyranose forms of these monosaccharides in ²H₂O. In some cases spectral interpretation was assisted by the use of one-dimensional INADEQUATE ¹³C spectra. The effect of aldopyranose and aldofuranose ring structure and conformation on the magnitudes of these couplings, especially ²*J*_{CC} and ³*J*_{CCC}, was probed. Results show that ²*J*_{CC} is highly affected by the orientation of terminal hydroxyl substituents along the C–C–C coupling pathway and that ³*J*_{CCC} is not only affected by molecular dihedral angle (i.e., Karplus relationships) but also by substituent geometry along the C–C–C–C coupling pathway.

Introduction

In recent years, nuclear magnetic resonance (NMR) spectroscopy has emerged as a powerful tool to investigate the structures and conformational features of biologically-important molecules in solution. The development of multidimensional modes of data collection^{1,2} has played a dominant role in this regard, especially in studies of macromolecules such as proteins and nucleic acids. Implicit in these new methods is the fundamental assumption that an intelligent integration of different NMR parameters can lead to more reliable models of solution behavior. For example, the combined use of ¹H–¹H spin couplings (*J*_{HH}) and nOes, measured from COSY and NOESY spectra, respectively, has been important in computer-aided three-dimensional structure determinations of proteins.^{3,4} Thus, studies aimed at an improved understanding of how specific NMR parameters are affected by molecular structure and dynamics are critical to the development of NMR-based strategies to probe the solution properties of molecules.

While numerous NMR studies of carbohydrates have used ¹H–¹H spin couplings to assess molecular structure and conformation,⁵ interest in ¹³C–¹H (*J*_{CH}) and ¹³C–¹³C (*J*_{CC}) spin couplings is increasing, partly because modern NMR methods are available that permit their measurement without the need for ¹³C-enrichment.^{6,7} Thus, while the problem of measurement has been reduced, a real need exists for systematic investigations of the dependencies of these couplings on carbohydrate structure. This

need is particularly acute for *J*_{CC}, since it is well recognized that relatively subtle changes in structure along the coupling pathway may dramatically affect their magnitudes.⁸ Seminal studies in non-carbohydrate systems conducted by Barfield and co-workers^{9–11} have clearly shown that *J*_{CC} depends highly on pathway

(1) (a) Ernst, R. R.; Bodenhausen, G.; Wokaun, A. *Principles of Nuclear Magnetic Resonance in One and Two Dimensions*; Oxford University Press: New York, 1987. (b) *Pulse Methods in 1D and 2D Liquid-Phase NMR*; Brey, W. S., Ed.; Academic Press: New York, 1988.

(2) (a) Vuister, G. W.; de Waard, P.; Boelens, R.; Vliegthart, J. F. G.; Kaptein, R. *J. Am. Chem. Soc.* **1989**, *111*, 772. (b) Fesik, S. W.; Gampe, R. T., Jr.; Zuiderweg, E. R. P. *J. Am. Chem. Soc.* **1989**, *111*, 770. (c) Kay, L. E.; Clore, G. M.; Bax, A.; Gronenborn, A. M. *Science* **1990**, *249*, 411.

(3) Wüthrich, K. *NMR of Proteins and Nucleic Acids*; John Wiley and Sons: New York, 1986.

(4) (a) Bax, A. *Ann. Rev. Biochem.* **1989**, *58*, 223. (b) Clore, G. M.; Gronenborn, A. M. *Crit. Rev. Biochem. Mol. Biol.* **1989**, *24*, 479.

(5) (a) For a general discussion of the use of *J*_{HH} in the conformational analysis of cyclic compounds, see: Booth, H. *Prog. NMR Spectrosc.* **1969**, *5*, 149. (b) Bentley, R. *Ann. Rev. Biochem.* **1972**, *41*, 953.

(6) (a) Bax, A.; Freeman, R. *J. Am. Chem. Soc.* **1982**, *104*, 1099. (b) Morat, C.; Taravel, F. R.; Vignon, M. R. *Magn. Reson. Chem.* **1988**, *26*, 264.

(7) (a) Bax, A.; Freeman, R.; Kempell, S. P. *J. Am. Chem. Soc.* **1980**, *102*, 4849. (b) Bax, A.; Freeman, R.; Frenkiel, T. A.; Levitt, M. H. *J. Magn. Reson.* **1980**, *43*, 478.

(8) Marshall, J. L. *Carbon–Carbon and Carbon–Proton NMR Couplings: Applications to Organic Stereochemistry and Conformational Analysis*; Verlag Chemie: Weinheim/Bergstrasse, Germany, 1983.

(9) (a) Barfield, M.; Burfitt, I.; Doddrell, D. *J. Am. Chem. Soc.* **1975**, *97*, 2631. (b) Barfield, M.; Conn, S. A.; Marshall, J. L.; Miiller, D. E. *J. Am. Chem. Soc.* **1976**, *98*, 6253.

(10) Marshall, J. L.; Conn, S. A.; Barfield, M. *Org. Magn. Reson.* **1977**, *9*, 404.

[†]University of Notre Dame.

[‡]Omicron Biochemicals, Inc.

[§]Helsinki University of Technology.